

AQ27COM-02 Series

27 V Bidirectional 200 W TVS Diode Array, General Purpose ESD Protection

PRELIMINARY & CONFIDENTIAL

Littelfuse, Inc. has characterized initial samples of this device and is currently conducting reliability testing. Parts numbers and specifications are subject to change until the datasheet is made final.
Confidential and proprietary



Description

The AQ27COM-02 series bidirectional TVS are fabricated in a proprietary silicon avalanche technology. These diodes provide a high ESD (electrostatic discharge) protection level for electronic equipment.

The AQ27COM-02 series TVS can safely absorb repetitive ESD strikes of ± 30 kV (contact and air discharge as defined in IEC 61000-4-2) without any performance degradation. In addition, it can safely dissipate a 4 A 8/20 μ s surge event as defined in IEC 61000-4-5, 2nd edition.

Pinout

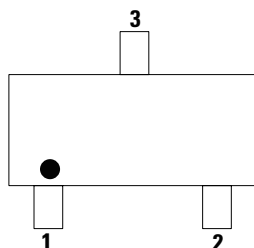

Features

- ESD, IEC 61000-4-2, ± 30 kV contact/air
- ESD, ISO 10605, 330 pF 330 Ω , ± 30 kV contact/air
- EFT, IEC 61000-4-4, 40 A (5/50 ns)
- Maximum surge tolerance, IEC 61000-4-5 2nd edition, 4A (8/20 μ s)
- Halogen free, lead free and RoHS compliant
- Moisture sensitivity level (MSL-1)
- AEC-Q101 qualified and PPAP capable

Functional Block Diagram

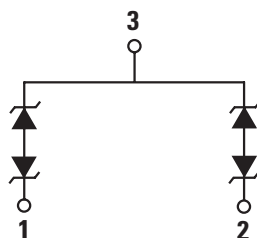

Applications

- Automotive Applications
- ADAS Control Units
- Body Control Units
- CAN Bus
- Electronic Control Units
- Factory Automation
- Lighting Control (DALI)
- PowerTrain Control Units

Life Support Note:

Not Intended for Use in Life Support or Life Saving Applications

The products shown herein are not designed for use in life sustaining or life saving applications unless otherwise expressly indicated.

AQ27COM-02 Series

27 V Bidirectional 200 W TVS Diode Array, General Purpose ESD Protection

PRELIMINARY & CONFIDENTIAL

Littelfuse, Inc. has characterized initial samples of this device and is currently conducting reliability testing. Parts numbers and specifications are subject to change until the datasheet is made final. Confidential and proprietary.

Absolute Maximum Ratings

Symbol	Parameter	Value	Units
P_{PK}	Peak Pulse Power ($t_p = 8/20 \mu s$)	200	W
I_{PP}	Peak Current ($t_p = 8/20 \mu s$)	4.0	A
T_{OP}	Operating Temperature	-40 to 150	°C
T_{STOR}	Storage Temperature	-55 to 150	°C

CAUTION: Stresses above those listed in "Absolute Maximum Ratings" may cause permanent damage to the component. This is a stress only rating and operation of the component at these or any other conditions above those indicated in the operational sections of this specification is not implied.

Electrical Characteristics ($T_{OP} = 25 \text{ }^\circ\text{C}$)

Parameter	Symbol	Test Conditions	Min	Typ	Max	Units
Reverse Standoff Voltage	V_{RWM}	Pin 1 or Pin2 to Pin 3			27	V
Breakdown Voltage	V_{BR}	$I_R = 1 \text{ mA}$, Pin 1 or Pin2 to Pin 3	28		35	V
Reverse Leakage Current	I_{LEAK}	$V_R = 27 \text{ V}$		10	50	nA
Clamp Voltage ¹	V_C	$I_{PP} = 1 \text{ A}$, $t_p = 8/20 \mu s$, Pin 1 or Pin2 to Pin 3		40.5		V
		$I_{PP} = 4 \text{ A}$, $t_p = 8/20 \mu s$, Pin 1 or Pin2 to Pin 3		50		V
Dynamic Resistance ^{1,2}	R_{DYN}	TLP, $t_p = 100 \text{ ns}$, Pin 1 or Pin2 to Pin 3		0.5		Ω
ESD Withstand Voltage ^{1,3,4}	V_{ESD}	IEC 61000-4-2 (Contact Discharge)	± 30			kV
		IEC 61000-4-2 (Air Discharge)	± 30			kV
		ISO 10605 (Contact Discharge)	± 30			kV
		ISO 10605 (Air Discharge)	± 30			kV
Diode Capacitance ¹	$C_{I/O-GND}$	Reverse Bias = 0 V, $f = 1 \text{ MHz}$; Pin 1 or Pin 2 to Pin 3		12		pF

Note:

- Parameter is guaranteed by design and/or component characterization.
- Transmission Line Pulse (TLP) with 100ns width, 0.2 ns rise time, and average window $t_1 = 70 \text{ ns}$ to $t_2 = 90 \text{ ns}$
- Device stressed with ten non-repetitive ESD pulses according to IEC61000-4-2 ($R = 330 \Omega$, $C = 150 \text{ pF}$).
- Device stressed with three non-repetitive ESD pulses according to ISO10605 ($R = 330 \Omega$, $C = 330 \text{ pF}$).

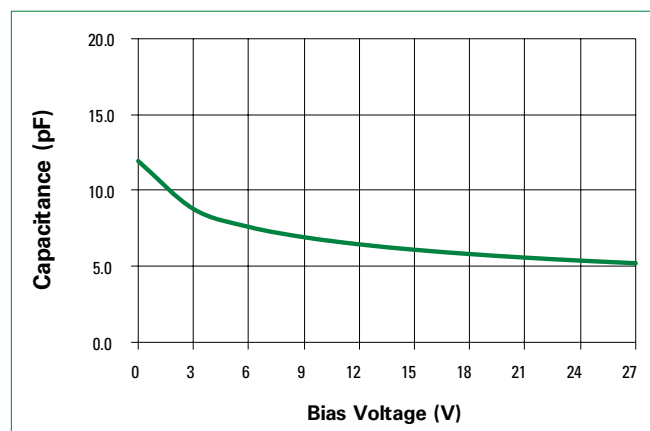
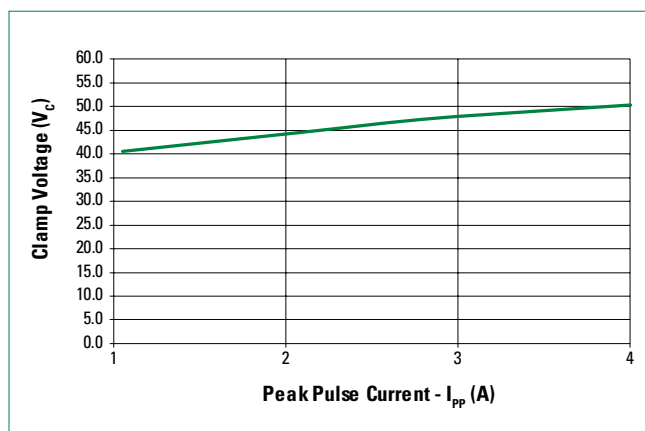
Capacitance vs. Reverse Bias**Clamping Voltage vs I_{PP}** 

AQ27COM-02 Series

27 V Bidirectional 200 W TVS Diode Array, General Purpose ESD Protection

PRELIMINARY & CONFIDENTIAL
 Littelfuse, Inc. has characterized initial samples of this device and is currently conducting reliability testing. Parts numbers and specifications are subject to change until the datasheet is made final.
 Confidential and proprietary.

Positive Transmission Line Pulsing (TLP) Plot

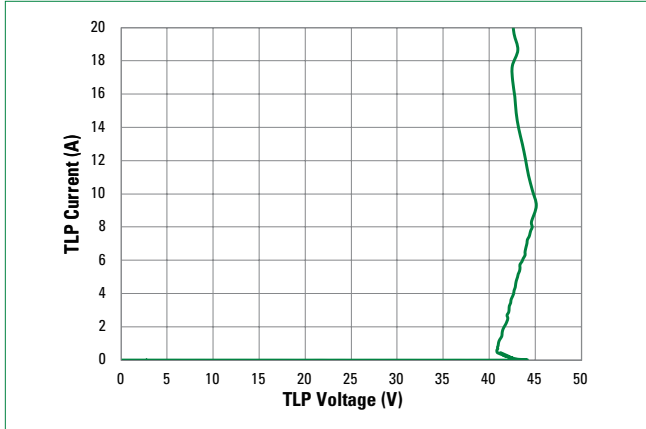

Negative Transmission Line Pulsing (TLP) Plot

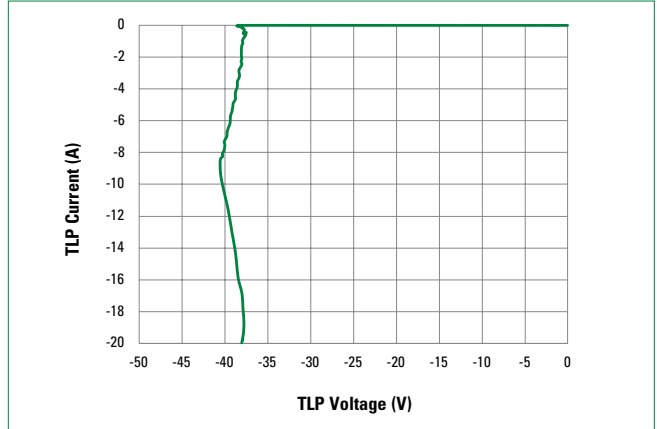

IEC 61000-4-2 +8 kV Contact ESD Clamping Voltage

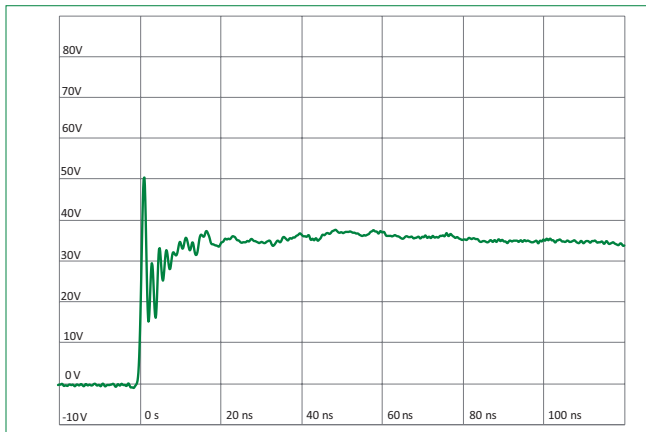

IEC 61000-4-2 -8 kV Contact ESD Clamping Voltage



ISO10605 Contact Discharge Plot at +8 kV

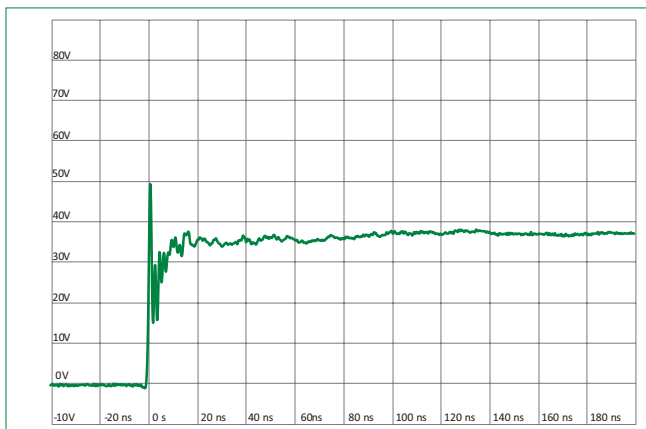

ISO10605 Contact Discharge Plot at -8 kV

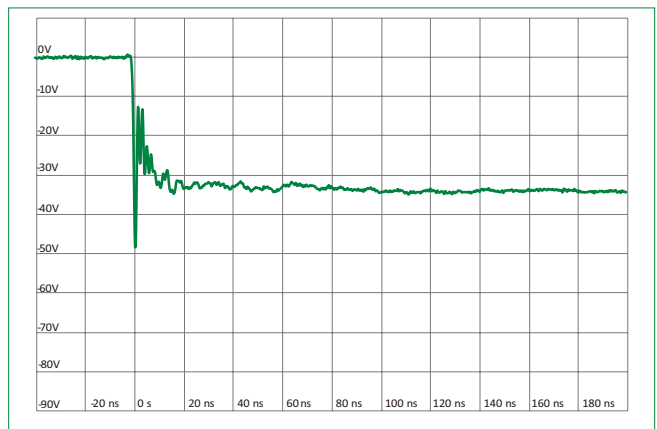

AQ27COM-02 Series

27 V Bidirectional 200 W TVS Diode Array, General Purpose ESD Protection

PRELIMINARY & CONFIDENTIAL

Littelfuse, Inc. has characterized initial samples of this device and is currently conducting reliability testing. Parts numbers and specifications are subject to change until the datasheet is made final. Confidential and proprietary.

Soldering Parameters

Reflow Condition		Pb – free assembly
Pre Heat	- Temperature Min ($T_{s(min)}$)	150 °C
	- Temperature Max ($T_{s(max)}$)	200 °C
	- Time (min to max) (t_s)	60 – 120 seconds
Average Ramp Up Rate (Liquidus) Temp (T_L) to Peak		3 °C/second max
$T_{S(max)}$ to T_L - Ramp-up Rate		3 °C/second max
Reflow	- Temperature (T_L) (Liquidus)	217 °C
	- Temperature (t_L)	60 – 150 seconds
Peak Temperature (T_p)		260 ^{+0/-5} °C
Time Within 5 °C of Actual Peak Temperature (t_p)		30 seconds
Ramp-down Rate		6 °C/second max
Time 25 °C to Peak Temperature (T_p)		8 minutes max
Do Not Exceed		260 °C

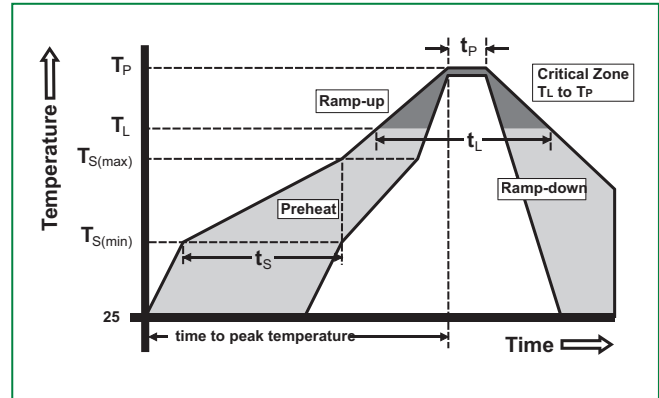
**Ordering Information**

Part Number	Package	Marking	Min. Order Qty.
AQ27COM-02JTG	SC70-3	AI**	3000
AQ27COM-02HTG	SOT23-3	BA**	3000

Product Characteristics

Lead Plating	Matte tin
Lead Material	Copper alloy
Body Material	Molded compound
Flammability	UL recognized compound meeting flammability rating V-0

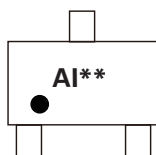
Part Marking System

AI = Part code
 * = Assembly code
 * = Date code

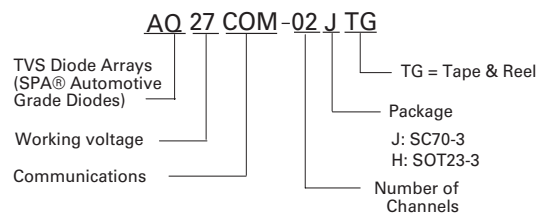
Part Numbering System

AQ27COM-02 Series

27 V Bidirectional 200 W TVS Diode Array, General Purpose ESD Protection

PRELIMINARY & CONFIDENTIAL

Littelfuse, Inc. has characterized initial samples of this device and is currently conducting reliability testing. Parts numbers and specifications are subject to change until the datasheet is made final. Confidential and proprietary.

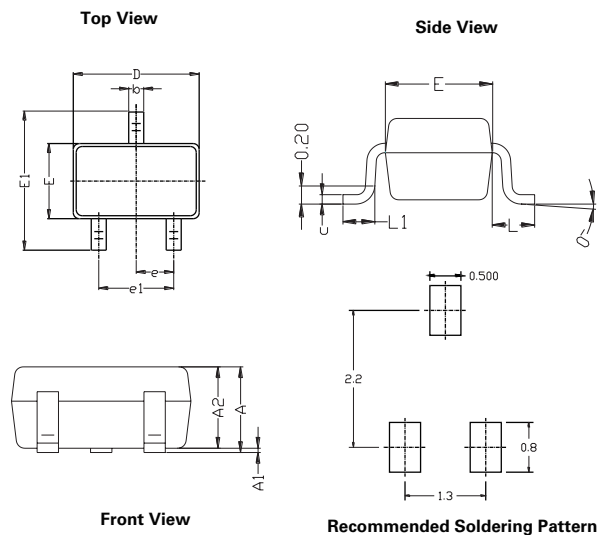
Package Dimensions - SC70-3

Symbol	Millimeters		Inches	
	Min	Max	Min	Max
A	0.90	1.10	0.035	0.043
A1	0.00	0.10	0.000	0.004
A2	0.90	1.00	0.035	0.039
b	0.20	0.40	0.008	0.016
C	0.08	0.15	0.003	0.006
D	2.00	2.20	0.079	0.087
E	1.15	1.35	0.045	0.053
E1	2.15	2.40	0.085	0.094
e	0.650 Typ		0.026 Typ	
e1	1.20	1.40	0.047	0.055
L	0.53 Ref		0.021 Ref	
L1	0.26	0.45	0.010	0.018
θ	0°	8°	0°	8°

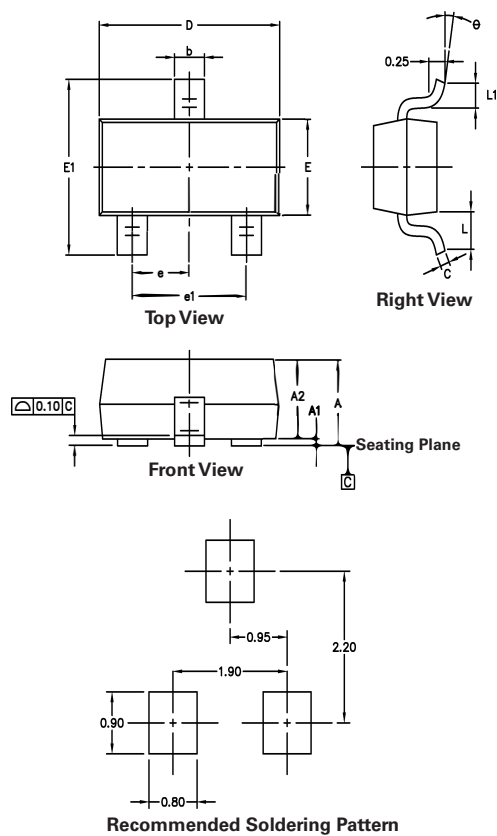
Package Dimensions - SOT23-3

Package	SOT23-3			
Pins	3			
Symbol	Millimeters		Inches	
	Min	Max	Min	Max
A	0.880	1.150	0.035	0.045
A1	0.000	0.100	0.000	0.004
A2	0.880	1.050	0.035	0.041
b	0.300	0.510	0.012	0.020
C	0.080	0.200	0.003	0.008
D	2.800	3.040	0.110	0.120
E	1.200	1.400	0.047	0.055
E1	2.100	2.640	0.083	0.104
e	0.950 Typ		0.037 Typ	
e1	1.780	2.050	0.070	0.081
L	0.550 Ref		0.022 Ref	
L1	0.300	0.550	0.012	0.022
θ	0°	8°	0°	8°

AQ27COM-02 Series

27 V Bidirectional 200 W TVS Diode Array, General Purpose ESD Protection

PRELIMINARY & CONFIDENTIAL

Littelfuse, Inc. has characterized initial samples of this device and is currently conducting reliability testing. Parts numbers and specifications are subject to change until this datasheet is made final. Confidential and proprietary.

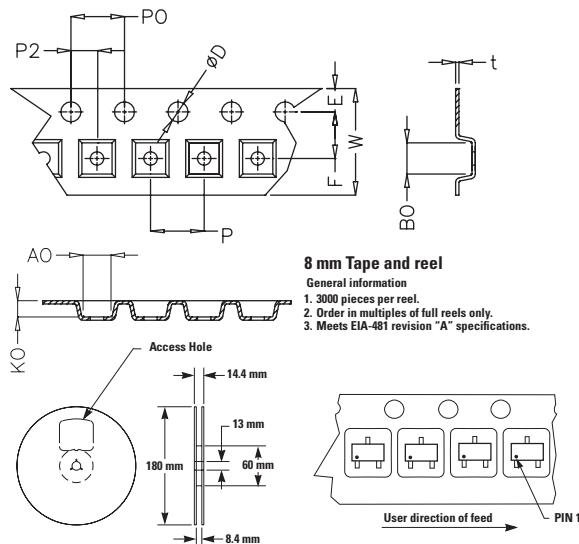
Embossed Carrier Tape & Reel Specification - SC70-3

Symbol	Millimeters		Inches	
	Min	Max	Min	Max
E	1.65	1.85	0.065	0.073
F	3.45	3.55	0.136	0.140
P2	1.95	2.05	0.077	0.081
D	1.50	1.60	0.059	0.063
P0	3.90	4.10	0.154	0.161
W	7.90	8.30	0.311	0.327
P	3.90	4.10	0.154	0.161
A0	2.15	2.35	0.085	0.093
B0	2.45	2.65	0.096	0.104
K0	1.09	1.29	0.043	0.051
t	0.18	0.22	0.007	0.009

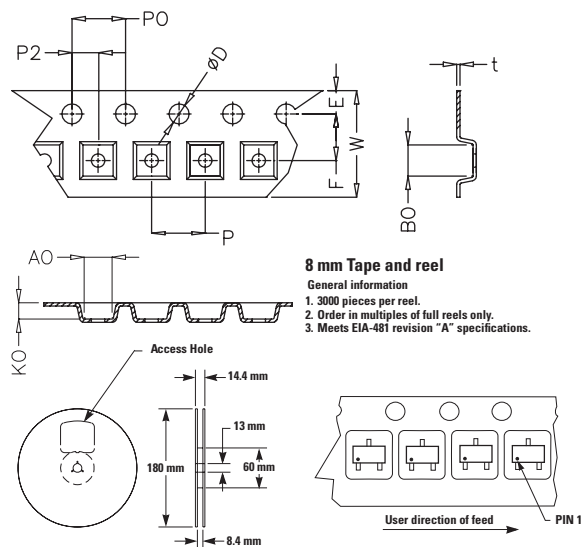
Embossed Carrier Tape & Reel Specification – SOT23-3

Symbol	Millimeters		Inches	
	Min	Max	Min	Max
E	1.65	1.85	0.065	0.073
F	3.40	3.60	0.134	0.142
P2	1.90	2.10	0.075	0.083
D	1.40	1.60	0.055	0.063
P0	3.90	4.10	0.154	0.161
W	7.70	8.30	0.303	0.327
P	3.90	4.10	0.154	0.161
A0	3.05	3.25	0.120	0.128
B0	2.67	2.87	0.105	0.113
K0	1.12	1.32	0.044	0.052
t	0.18	0.24	0.007	0.009

Product Disclaimer: Littelfuse products are not designed for, and shall not be used for, any purpose (including, without limitation, automotive, military, aerospace, medical, life-saving, life-sustaining or nuclear facility applications, devices intended for surgical implant into the body, or any other application in which the failure or lack of desired operation of the product may result in personal injury, death, or property damage) other than those expressly set forth in applicable Littelfuse product documentation. Warranties granted by Littelfuse shall be deemed void for products used for any purpose not expressly set forth in applicable Littelfuse documentation. Littelfuse shall not be liable for any claims or damages arising out of products used in applications not expressly intended by Littelfuse as set forth in applicable Littelfuse documentation. The sale and use of Littelfuse products is subject to Littelfuse Terms and Conditions of Sale, unless otherwise agreed by Littelfuse. "Littelfuse" includes Littelfuse, Inc., and all of its affiliate entities. <http://www.littelfuse.com/disclaimer-electronics>.