

Halogen free

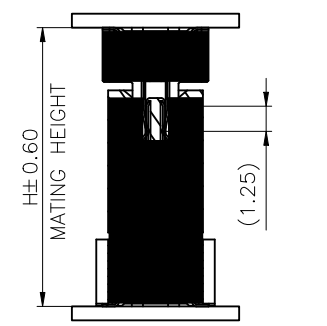
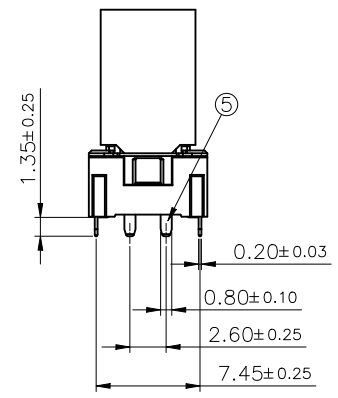
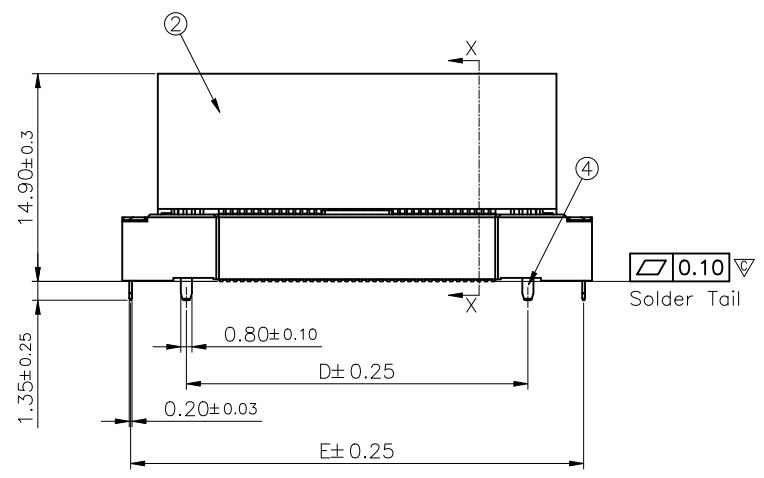
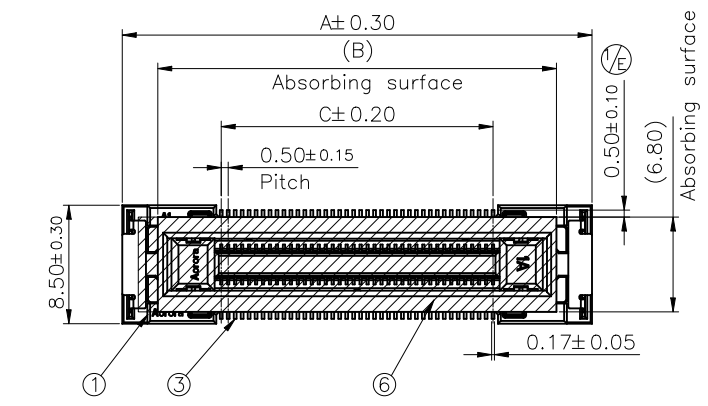

Mating Height List	H	
	18.00	25.00
20.00	26.00	
21.00	28.00	
22.00	30.00	
24.00		

DIMENSION LIST:

PIN No.	A	B	C	D	E
10	16.20	11.10	2.00	7.00	15.00
20	18.70	13.60	4.50	9.50	17.50
30	21.20	16.10	7.00	12.00	20.00
40	23.70	18.60	9.50	14.50	22.50
50	26.20	21.10	12.00	17.00	25.00
60	28.70	23.60	14.50	19.50	27.50
70	31.20	26.10	17.00	22.00	30.00
80	33.70	28.60	19.50	24.50	32.50
90	36.20	31.10	22.00	27.00	35.00
AO(100)	38.70	33.60	24.50	29.50	37.50
BO(120)	43.70	38.60	29.50	34.50	42.50
DO(140)	48.70	43.60	34.50	39.50	47.50

- NOTES:  
 1. BURRS OF CONTACT AREA ARE NOT ALLOWED AND INTERPOSITION AREA SHOULD BE 0.03MM MAX.  
 2. "▽" MARK IS CRITICAL CHARACTERISTIC DIMENSION.  
 3. ALL MATERIAL MUST BE COMPLIANT RoHS.  
 4. PART NO.: B04R-3J1B1-AA180-1110

PIN No.:80PIN

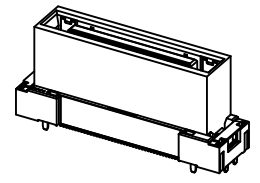

REV.	ECR/ECN No.	DESCRIPTION	DRAWN/DATE	CHECKED/DATE	APPROVED/DATE
C	/	Add PIN No. of 30PIN	SH Chen 2023-03-31	Elven 2023-03-31	Rain 2023-03-31
D	/	Add Mating Height 21.0	SH Chen 2023-05-17	Elven 2023-05-17	Rain 2023-05-17
E	/	Add dimension for tail length	SH Chen 2023-12-25	Elven 2023-12-25	Rain 2023-12-25

NO.	COMPONENTS	MATERIALS	SPECIFICATION:FINISH/COLOR	QTY.
1	OUTER HOUSING	GLASS FILLED LCP UL94V-0	BLACK	1
2	INNER HOUSING	GLASS FILLED LCP UL94V-0	BLACK	1
3	SIGNAL CONTACT	COPPER ALLOY T=0.15mm	ALL OVER Ni UNDER PLATING:40u''~120u'' CONTACT AREA: Au 4u'' MIN. SOLDER AREA: Au 2u''Min.	N
4	POWER CONTACT	COPPER ALLOY T=0.20mm	ALL OVER Ni UNDER PLATING:40u''~120u'' CONTACT AREA: Au 4u'' MIN. SOLDER AREA: Au 2u''Min.	4
5	FIXING TAB	SUS304 T=0.20mm	ALL OVER Ni UNDER PLATING:40u''~120u'' SOLDER AREA: Au 2u''Min.	2
6	MYLAR	THERMOSTABLE T=0.10mm	YELLOW	1

UNLESS OTHERWISE SPECIFIED TOLERANCES		ANGLE OF PROJECTION	
X.	±0.30	X.	± 5'
X.X	±0.25	X.X	± 4'
X.XX	±0.20	X.XX	± 3'
X.XXX	±0.15	X.XXX	± 2'
LINEAR DIMS		ANGLES DIMS	
DWG NO.:	A-S0741	DOC TYP	Customer Drw
MATERIAL	SEE NOTES	DRAWN DATE	SH Chen 2023-12-25
FINISHED	SEE NOTES	DESIGN DATE	SH Chen 2023-12-25
		CHECKED DATE	Elven 2023-12-25
		APPROVED DATE	Rain 2023-12-25

**Amphenol AORORA**  
 Amphenol Aorora Technology (Huizhou) Co.,Ltd

TITLE: 0.5mm Pitch Floating BTB Rece Conn.

SIZE: A4 PART NUMBER: B04R-3J1B1-AA1\*\*-1110 REV. E

SCALE: 2:1 UNIT: mm SHEET 1 OF 3

This document is the property of and embodies CONFIDENTIAL and PROPRIETARY information of AOR. No part of the information shown on this document may be used in any way or disclosed to others without the written consent of AOR. © 2019 AOR

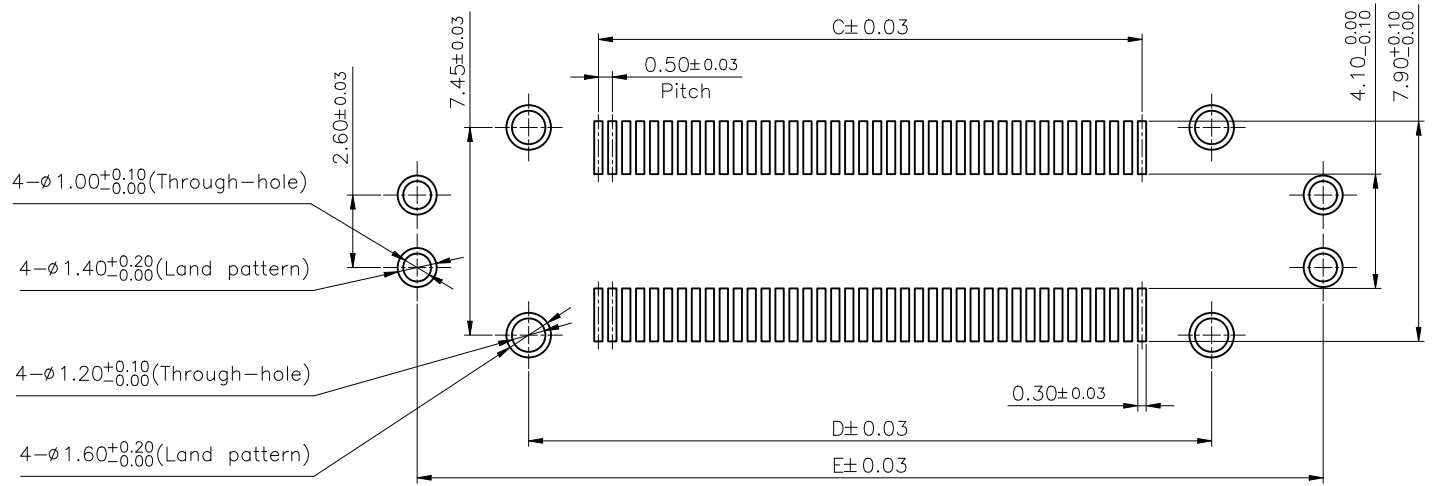

RECOMMENDED PCB SIZE  
FOR COMMON DIFFERENTIAL PAIR 100ohm

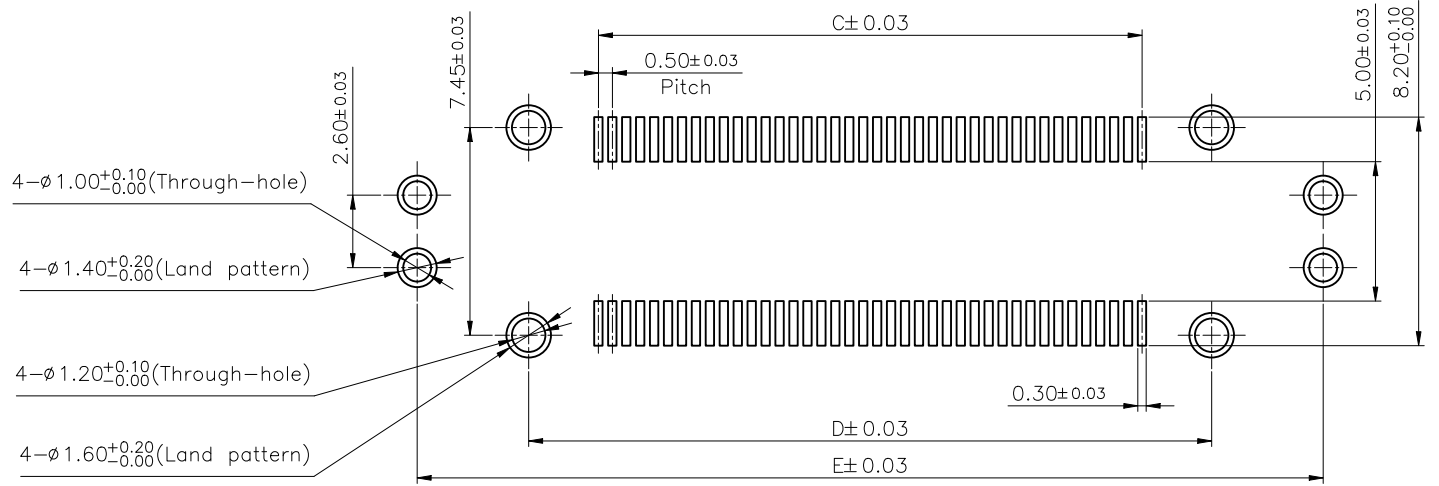

RECOMMENDED PCB SIZE  
FOR PCIe Gen4.0 85ohm

This document is the property of and embodies CONFIDENTIAL and PROPRIETARY information of AOR. No part of the information shown on this document may be used in any way or disclosed to others without the written consent of AOR. © 2019 AOR



UNLESS OTHERWISE SPECIFIED TOLERANCES			ANGLE OF PROJECTION		 Amphenol Aorora Technology (Huizhou) Co.,Ltd			
X.	±0.30	X. '	± 5'					
X.X	±0.25	X.X '	± 4'	DOC		TITLE:		
X.XX	±0.20	X.XX '	± 3'	Customer Drw				
X.XXX	±0.15	X.XXX '	± 2'	DRAWN	SH Chen	0.5mm Pitch Floating BTB Rece Conn.		
LINEAR DIMS	ANGLES DIMS		DATE	2023-12-25				
DWG NO.:	A-S0741			DESIGN	SH Chen	SIZE	PART NUMBER:	REV.
MATERIAL	SEE NOTES			DATE	2023-12-25	A4	B04R-3J1B1-AA1**-1110	E
FINISHED	SEE NOTES			CHECKED	Elven	SCALE	4:1	UNIT : mm
				DATE	2023-12-25	SHEET	2	OF 3

PULL OUT DIRECTION

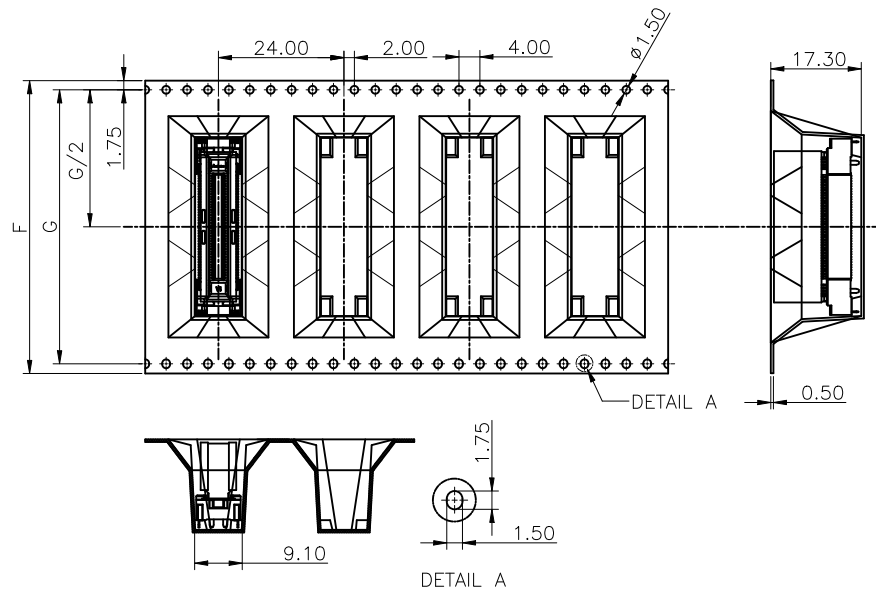

5. QTY LIST:

DIM \ NO.	10~50pin	60~90pin	100~140pin
F	44.00	56.00	72.00
G	40.40	52.40	68.40
N	6	5	4
TOTAL(PCS)	1200	1000	800

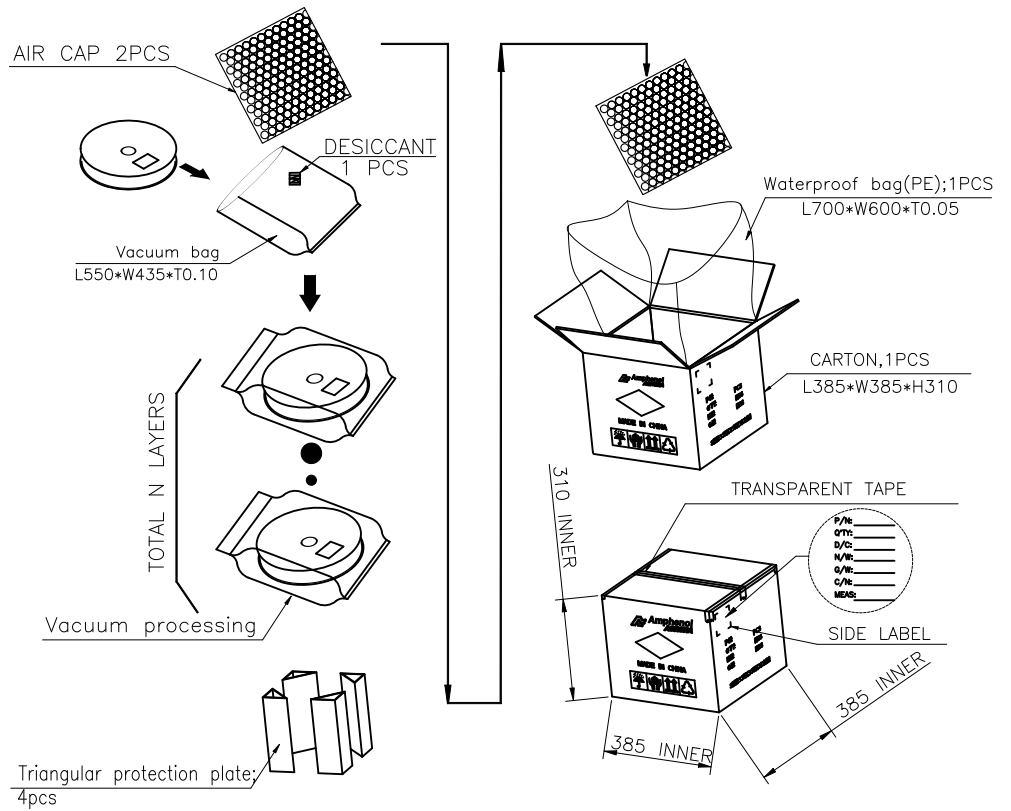

B

Amphenol AORORA

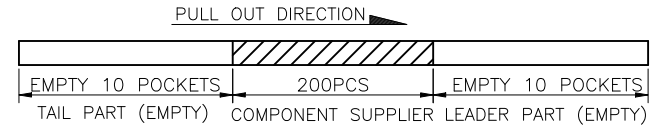
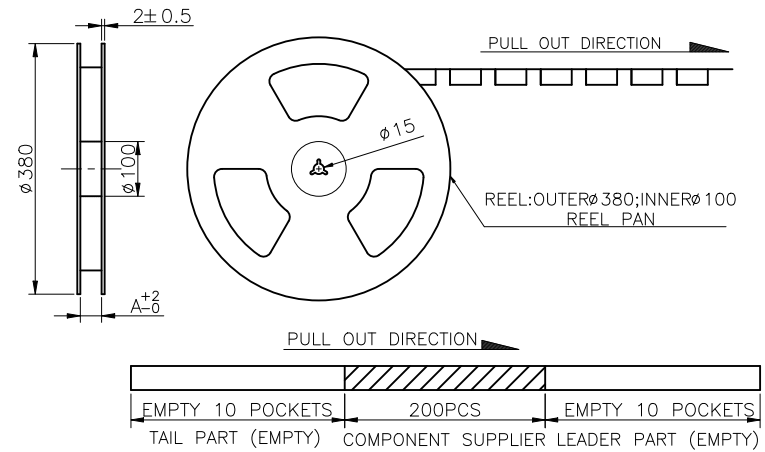

NOTES:

- MATERIAL:
  - CARRY TAPE:HIPS,T=0.50mm,CLEAR
  - REEL:HIPS,BLUE.
  - SHIM:PE,CLEAR.
- PRIMARY PACKING:200PCS/REEL.
- SECONDARY PACKING:"N" REELS/CARTON ("TOTAL"=N\*200/CARTON).
- PEELING RESISTANCE: 0.4N~1.4N(40~140gf);  
PEELING ANGLE: 165°~180°;  
PEELING SPEED: 300mm/minutes.

UNLESS OTHERWISE SPECIFIED TOLERANCES		ANGLE OF PROJECTION		Amphenol AORORA	
X.	±0.30	X. '	± 5'	Amphenol Aorora Technology (Huizhou) Co.,Ltd	
X.X	±0.25	X.X '	± 4'	TITLE: 0.5mm Pitch Floating BTB Rece Conn.	
X.XX	±0.20	X.XX '	± 3'	Customer Drw	SIZE PART NUMBER: B04R-3J1B1-AA1**-1110
X.XXX	±0.15	X.XXX '	± 2'	Customer Drw	REV. E
LINEAR DIMS		ANGLES DIMS		SCALE 1:1	UNIT : mm
DWG NO.:	A-S0741	APPROVED DATE	Rain 2023-12-25	SHEET 3 OF 3	
MATERIAL	SEE NOTES	CHECKED DATE	Elven 2023-12-25		
FINISHED	SEE NOTES	DESIGN DATE	SH Chen 2023-12-25		
		DATE	SH Chen 2023-12-25		

This document is the property of and embodies CONFIDENTIAL and PROPRIETARY information of AOR. No part of the information shown on this document may be used in any way or disclosed to others without the written consent of AOR. © 2019 AOR